

M-CLAD 24

Air-insulated Withdrawable Switchgear
Metal-Clad (LSC2B)



according to

3B Energy can propose a huge number of Products related to Energy sector. We are active in the whole world of Power Transmission and Distribution. Medium Voltage switchgears, Medium Voltage switches, Low Voltage PC, Low Voltage MCCs with fix and withdrawable units, Transformers, Cabinets; 3B Energy can propose a wide range of Products for fulfilling any request and need.

3B Energy is very active and smart in assisting customers for finding Solutions related to Energy sector. We can support the customer during engineering phase of the plant, during purchasing steps, for the supply and after-sales services. 3B Energy is a real "turnkey" Solution provider; Package Substations, Transformer Substations, Mobile Cabinets; we can propose a complete solution set for letting the customer have one player only for his whole plant.

3B Energy can propose a complete and detailed list of Services which can cover each step of Engineering phase. Our technical staff is highly expert and professional and can support the customer starting from the base design of a single component till a complete apparatus for electrical application. We can design and project every component the customer may need: a single contact or a complete switching device, we can develop and engineer the technology for any product or application of Energy sector

1. Summary

1.1 General

(Figure 1/1)

M CLAD - 24 air-insulated metal-clad withdrawable switchgear (hereinafter as “switchgear”) manufactured by 3B Energy is a necessary power distribution equipment in 3.6-24 kV 3-phase AC 50Hz single busbar sectional power system. It is mainly used to distribute electrical power in power station and power generators of middle and small size, and receive and distribute power in secondary substations of mine, industry and electrical power supply system. Also it is used in control, protection and monitoring the start of large high voltage motors. The switchgear has perfect prevention functions to meet the requirements of standard IEC 62271-200 such as prevent the circuit breaker to be pulled out or pushed in with load, prevent the circuit breaker to be incorrectly opened or closed, prevent the circuit breaker to be closed when the earthing switch is closed, prevent anybody accidentally to access into the compartment, and prevent the earthing switch to be closed in alive. The switchgear could be fitted with center located withdrawable vacuum SF6 circuit breaker or other trucks like isolated truck, PT truck, fuses truck and so on. So it is an ideal power distribution equipment with perfect performance.



Figure 1/1 M CLAD - 24 Switchgear

1.2 Service Conditions

1.2.1 Normal Operating Conditions

- A. Ambient temperature: $-15^{\circ}\text{C} \sim +40^{\circ}\text{C}$
- B. Altitude: Not exceed 1000m above sea level
- C. Ambient humidity: Daily average RH $\leq 95\%$; Monthly average RH $\leq 90\%$
- D. Earthquake intensity: \leq Degree 8
- E. Ambient air is not obviously contaminated by corrosive or flammable gas or steam.
- F. Neither heavy pollution nor frequently strenuous vibration is occurred. Under harsh condition the strict design shall meet the requirement of class I .

1.2.2 Special Operating Conditions

According to IEC60694, the manufacturer and user may agree on special service conditions which deviate from the normal service conditions. To prevent the condensation phenomena, the heater is necessary for switchgear and needs to be put into service when the switchgear is in readiness and service conditions. The heat dissipation problem of switchgear can be sloved by ventilation facilities.

1.3 Overall Dimension and Weight

(Figure 1/2)

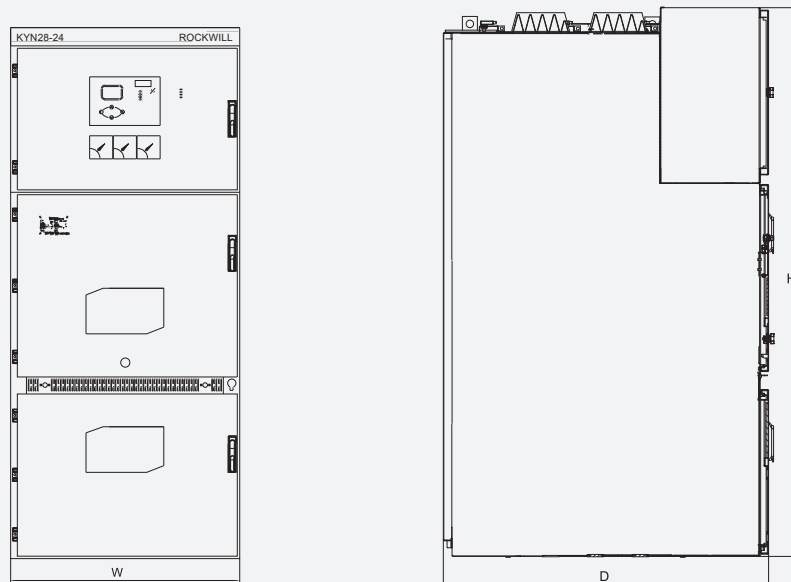

Figure 1/2 Overall Dimension Drawing

Height H (mm)		2400
Width W (mm)	Branch busbar rated current up to 1250 A	800
	Branch busbar rated current 1600 A and more	1000
Depth D (mm)	Cable incoming feeder and outgoing feeder	1800
Weight (kg)		840-1440

1.4 Technical Parameters

1.4.1 Switchgear Technical Parameters

Item	Unit	Parameters	
Rated Voltage	kV	24	
Rated Insulation Level	Lightning Impulse Withstand Voltage	kV	125
	1 min Power Frequency Withstand Voltage	kV	60
Rated Frequency	Hz	50/60	
Main Busbar Rated Current	A	630, 1250, 1600, 2000, 2500, 3150	
Branch Busbar Rated Current	A	630, 1250, 1600, 2000, 2500, 3150	
Rated Short-time Withstand Current(4s) *	kA	20, 25, 31.5	
Rated Peak Withstand Current	kA	50, 63, 80	
Protective Level	IP	IP4X for enclosure; IP2X between compartments and when the circuit breaker door is open.	

Note: * The short circuit capability of current transformer shall be considered separately.

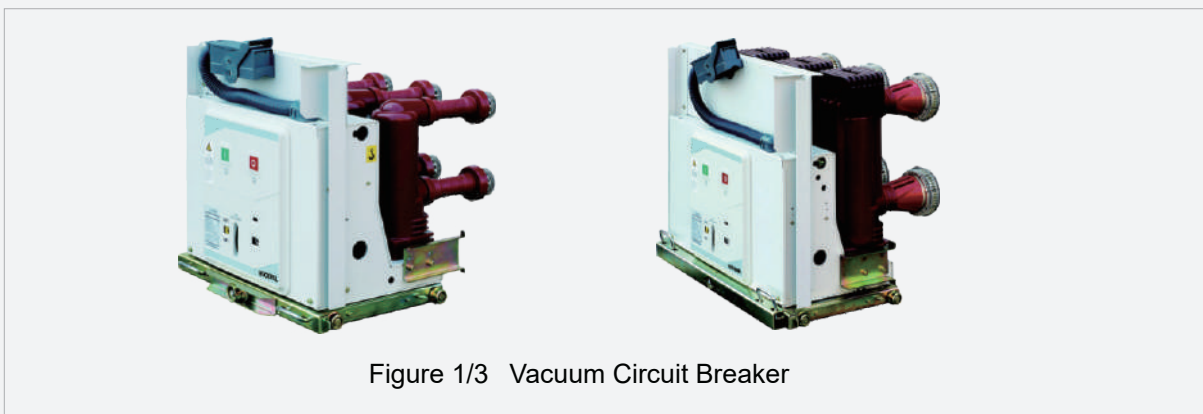

Figure 1/3 Vacuum Circuit Breaker

1.4.2 Vacuum Circuit Breaker Technical Parameters

(Figure 1/2 , 1/3)

NO.	Item	Unit	Parameters
1	Rated Voltage	kV	24
2	Rated Frequency	Hz	50/60
3	Rated Short-time Power Frequency Withstand Current (1 min)	kV	60
4	Rated Lightning Impulse Withstand Voltage (Peak)	kV	125
5	Rated Current	A	630 1250 1600 2000 2500 3150
6	Rated Short - Circuit Opening Current	kA	20 25 31.5
7	Rated Short-time Withstand Current (Valid)	kA	20 25 31.5
8	Rated Peak Withstand Current (Peak)	kA	50 63 80
9	Rated Short - Circuit Closing Current (Peak)	kA	50 63 80
10	Rated Duration of Short Circuit	s	4
11	Rated Single Capacitor Bank Opening Current	A	400
12	Rated Back-to-back Capacitor Bank Opening Current	A	400
13	Mechanical Endurance	Cycle	20000
14	Secondary Circuit Power Frequency Withstand Voltage (1 min)	V	2000
15	Rated Operating Sequence		O-0.3s-CO-180s-CO

Note: * 20000 is for products with rated short circuit bearing current 40kA or 50kA.

When the circuit breaker is used to control 3-10 kV motors, it is necessary to add metal-oxide arrester if the starting current is higher than 600A and the customer shall contact the manufacturer for the specific requirements. When the circuit breaker is used to break the capacitor bank, the rated current of the capacitor bank must not be higher than 80% of the rated current of the circuit breaker.

Recommended Operating Time

Item	VCB
Closing Time	35 ~ 70
Opening Time	20 ~ 50
Arcing Time (50Hz)	10 ~15
Breaking Time	30 ~ 65
Minimum Closing Command Duration (ms)	20ms ¹⁾ (100ms) ²⁾
Minimum Opening Command Duration (ms)	40ms ¹⁾ (100ms) ²⁾

Note: 1) Under the rated voltage of auxiliary circuit.

2) If the relay contact is started but it is failed to break the trip coil current.

Vacuum Circuit Breaker Spring-operated Mechanism Technical Parameters

Rated Voltage		Power ConsumptionVA/W	Energy Storage Time (Max) S
V		VCB	VCB
AC	110	70	15
	220	70	15
DC	110	70	15
	220	70	15

Opening and Closing Coil Current

Rated Voltage		Opening Coil Current (A)	Opening Coil Current (A)
V		VCB	VCB
AC	110	1.9~2.2	1.9~2.2
	220	1.1~1.3	1.1~1.3
DC	110	1.9~2.2	1.9~2.2
	220	1.1~1.3	1.1~1.3

2. Switchgear Structure and Equipment Installed

2.1 Structure

(Figure 2/1)

The switchgear is designed in accordance with the requirement of metal-clad switchgear under the standard IEC 62271-200. The switchgear is composed of the compartment body and center located withdrawable parts (i.e. withdrawable circuit breaker). The compartment body of the switchgear is divided into four independent compartments. The protective level of the enclosure is IP4X while the protective level is IP2X between the compartments and when the door of the circuit breaker compartment is open. Variable schemes are available such as overhead incoming feeder and outgoing feeder, cable incoming feeder and outgoing feeder and other functions. A number of power distribution equipment with different functions could be realized after arrangement and combination of various schemes. The erection, adjustment and maintenance could be undertaken in the front of the switchgear so that the switchgears could be back-to-back combined together in double arrangement or mounted against the wall. It has a high flexibility and safety with less floor space.

2.2 Enclosure

The enclosure of the switchgear is made of top quality imported aluminum-clad galvanized steel sheet. Through multiple edge-folding processing with CNC machine tool, the whole switchgear looks artistic and features solid, durable, low weight, accurate fitting, high corrosion resistance and oxidation resistance. The compartment body is of a modular structure and all parts are joined together with rivets so that the manufacturer is able to deliver the products promptly to meet any urgent order with its short lead-time.

2.3 Withdrawable Part

The manually moved withdrawable part consists of a robust sheet steel structure on which the circuit breaker poles are mounted and the breaker mechanism with ancillary components are installed. Contact arms with springloaded contact systems are fitted to the circuit-breaker poles. These create the electrical connection to the switchgear panel when the withdrawable part is inserted into the service position. Detailed information on the vacuum circuit breaker can be found in the corresponding instruction manual. The signalling, protection and control wiring between the switchgear panel and the withdrawable part is coupled by a multiple pin control wiring plug.

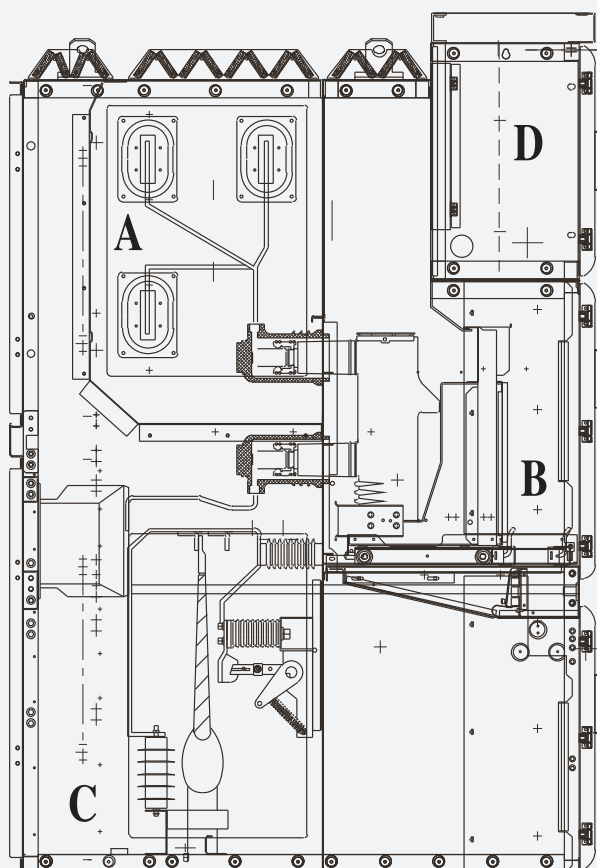

A. Busbar Compartment B. Circuit Breaker Compartment C. Cable Compartment D. Low Voltage Compartment

Figure 2/1 Withdrawable Switchgear Structure



Figure 2/2 M CLAD - 24 Switchgear

As soon as withdrawable part has been pushed into the switchgear panel and its interlock yoke has engaged in the test/disconnected position, it is positively connected to the switchgear panel. At the same time, it is earthed by earthing contacts and earthing rails. The position of the withdrawable part can be checked by the electrical position indicator or through the sight glass in the door of the circuit-breaker compartment at any time. The stored-energy spring mechanism of the circuit breaker including control parts and indicators is accessible at the front of the withdrawable part. Apart from the version with a fitted circuit breaker, withdrawable part with other equipments such as voltage transformer, is available.

2.4 C ompartment

All major electrical components of the switchgear have their own independent compartments, those are, circuit breaker compartment, busbar compartment, cable compartment and low voltage compartment. The protective level between compartments is IP2X. Except the low voltage compartment, all other three compartments are fitted with pressure relief plate individually. Because of center located arrangement, the cable compartment has sufficient space to be installed more cables.

2.4.1 Circuit Breaker Compartment B

(Figure 2/3 , 2/4)

The circuit breaker compartment B is fitted with the necessary guide rails to accommodate the withdrawable part, which can be moved between the service position and the test/disconnected position. If the withdrawable part is moved from the service position into the test/disconnected position, the fixed contacts located in the connection block in busbar compartment C and cable connection compartment D are automatically covered by metal plates which will be interlocked mechanically or can be locked by a padlock when the withdrawable part is moved away. In the test/disconnected position, the withdrawable part is still completely inside the panel with the door closed. The switching operations (including manual operation) are carried out with the doors closed.

2.4.2 Busbar Compartment A

The main busbar is made by individual unit busbar to be assembled and connected each other as shown on Fig.2/1 and it is held by branch busbar (spout) and main busbar support insulators. The main busbar and interbus are rectangular section copper bar and two rows of busbar assembly are used for high current load. The bolt is used to connect branch busbar with the spout and main busbar. For special requirement, the busbar could be covered by thermal shrinkable sleeve or insulation cover disposed with special process. The partition insulator is used on the busbars of neighbor compartments to maintain an air buffer between the connected busbars and to prevent busbar from melting due to fault arcing. The partition insulator can effectively prevent the fault from spreading to other compartments.

2.4.3 Cable Compartment C

With the center located arrangement of the switchgear, the cable compartment has big space. Both current transformer and earthing switch are mounted in the back of the compartment (according to customer requirement, the earthing switch also can be mounted at the middle of the switchgear.), and the arrester is mounted on the back bottom of the compartment. After the withdrawable part and withdrawable horizontal partition are moved away, worker can undertake internal erection and maintenance from the front of the switchgear. For the cable connecting conductors in the cable compartment, each phase can parallelly connect 1 to 3 cables and if necessary, each phase can parallelly connect 6 cables. The compartment bottom plate has slots and it is a removable nonmetal bottom plate or metal bottom plate without magnetic conductance for a convenient cable work.

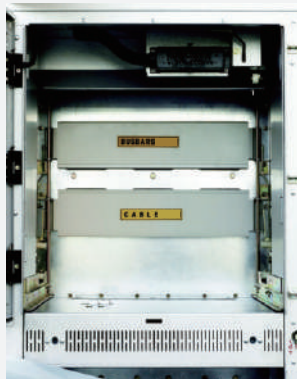

Figure 2/3 Circuit Breaker Compartment



Figure 2/4 Circuit Breaker Compartment

2.4.4 Low Voltage Compartment D

The relay protection element, instrument, charge indicator or any special secondary device can be mounted in the low voltage compartment. The control feeder is laid inside the raceway with sufficient space and metal cover so that the secondary wiring could be segregated from high voltage compartment. The left side raceway is for incoming and outgoing control feeders while the right side raceway is for internal wiring of the switchgear itself. For convenience in construction, on the top plate of the low voltage compartment, there are small holes for passing secondary busbar and the top cover plate of the compartment can turn over for erection of small secondary busbar.

2.5 Interlock/Protection Against Maloperation

A series of interlocks are provided to prevent fundamentally hazardous situations and maloperation, thus protecting both personnel and the switchgear itself. The interlocks which are normally individually effective are as follows:

- The withdrawable circuit breaker can only be moved from the test/disconnected position into the service position (and back) with the circuit breaker open and the earthing switch open (Mechanical interlock).
- The circuit breaker can only be closed when the withdrawable circuit breaker is precisely in the defined test position or service position (Mechanical interlock).
- The circuit breaker can only be opened manually in the service or test position when no control voltage is applied, and can not be closed (Electromechanical interlock).
- The circuit breaker can be only closed when withdrawable circuit breaker is in the test/disconnected position or removable position (Mechanical interlock).
- Earthing switch can only be closed when the withdrawable circuit breaker is in the test/disconnected position or the removed position (Mechanical interlock).
- The withdrawable circuit breaker cannot be moved from the test/disconnected position into the service position when the earthing switch is closed (Mechanical interlock).
- The secondary control plug of circuit breaker is locked when withdrawable circuit breaker is in the service position.

2.6 Pressure Relief Device

The pressure relief devices are equipped on the top of the circuit breaker compartment, busbar compartment and cable compartment. In case fault arcing is occurred inside these three compartments, the special sealing ring seals the front door completely, and along with the increase of the gas pressure inside the compartment, the top mounted pressure relief metal cover plate will open automatically to release pressure and the high temperature gas to ensure operator and switchgear in a safe condition.

2.7 Interlock Between Secondary Plug and Withdrawable Part

The secondary plug is used to connect the switchgear with the withdrawable circuit breaker. The withdrawable contact of the secondary plug connects the withdrawable circuit breaker via nylon bellows and the secondary socket is mounted on the top right of the circuit breaker compartment. Only when the withdrawable circuit breaker is in disconnected/testing position, the secondary plug is allowed to plug in or unplug. When the withdrawable circuit breaker is in service position, the secondary plug is locked and cannot be unplugged due to some mechanical interlocks. Because the closing mechanism has been locked by the closing blocking electrical magnet, the operator can only open the withdrawable circuit breaker manually before the secondary plug connects with the withdrawable circuit breaker. For the same reason, the operator cannot close the circuit breaker manually.

Note: the closing blocking electrical magnet shall be equipped in accordance with customer requirement.

2.8 Charge Indicator

The charge indicator is installed in the switchgear to monitor the operation of the primary circuit. It consists of high sensor and indicator which are connected together by external wiring. This device is used to monitor whether the high-voltage circuit is in live. And it also can be equipped with electrical magnetic lock to ensure the front and back door not be opened when there are power on. So that operators don't make such mistakes as close earthing switchgear in live or access the compartments in live.

2.9 Condensation and Corrosion Prevention

To prevent switchgear from undesirable condensation due to high humidity or big change in climate condition, heaters need to be installed in the circuit breaker compartment and cable compartment individually to prevent them from insulation fault or metal corrosion under such unfavorable conditions.

2.10 Earthing Device

Inside the cable compartment, 5 x 40 mm² earthing copper bar is equipped specially and the copper row passes through the neighbor compartments and keeps a good contact with the compartment body to serve all direct earthing components and elements. The whole switchgear is assembled by aluminum clad galvanized steel sheet so that the whole array of compartments are in good earthing condition to ensure a security of operators when they contact the compartment body.

3. Erection and Commissioning

The switchgear should be erected in a dry and clean switch room with good ventilation. Before the erection of switchgear, the structure of switchgear foundation must be completed and also the switch room has been available and equipped with lightings and ventilation.

3.1 Mode of Foundation

(Figure 3/1)

3.1.1 The installation foundation of switchgear must be in compliance with the stipulations of the norm 《Specifications on Electrical Power Construction and Acceptance Inspection》 .

3.1.2 For the installation foundation of the switchgear, generally it needs two times pouring of concrete. The first time pouring of concrete is erection foundation of angle steel, square steel or channel steel. The second time pouring of concrete is for floor replenishment with a general thickness of 60 mm. When pouring the replenishment concrete, the concrete height should be 3-5 mm lower than the surface of the floor.

3.1.3 The foundation of switchgear installation is shown on Figure 3/1.

3.1.4 The installation of the foundation members must meet the installation quality specification with a tolerance of ± 1 mm within a measuring length of 1m.

3.2 Erection of Switchgear

(Figure 3/2 to 3/4)

Switchgear Width(W)	Switchgear Depth(D)	M	N	L
800	1800	630	800	1760
1000	1800	830	1000	1760

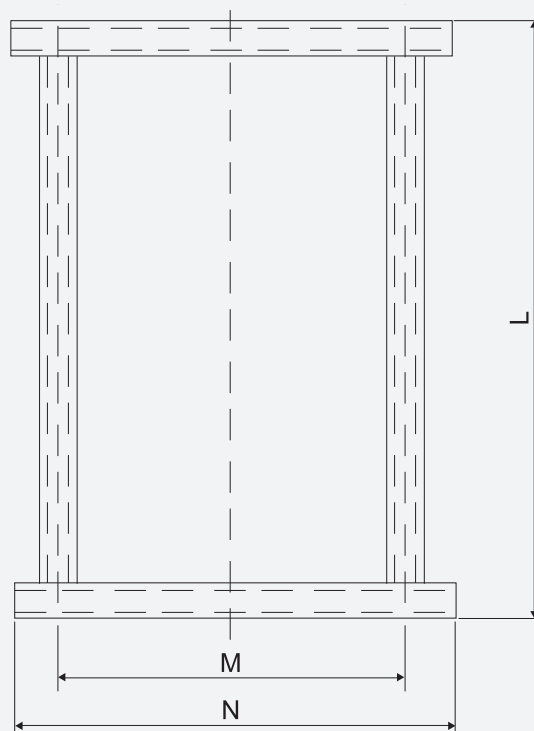

Figure 3/1 Foundation Drawing of Switchgear Installation

3.2.1 The foundation dimension and erection dimension of switchgear installation are shown in Figure 3/2 to 3/4.

3.2.2 For the arrangement of single array, an operator corridor of 2.5 m is appropriate in front of the switchgear while for the arrangement of two arrays, an operator corridor of 3 m is appropriate.

3.2.3 According to the specific project requirement and drawing notes, move the switchgears to the specific position. If the switchgear array is quite long (more than 10 sets of switchgear), start assembly from the center position should be necessary.

3.2.4 During transportation of the switchgear, only special transportation vehicles such as hoist or forklift is allowed to use. Both roll and crowbar are prohibited. Never attempt to push the withdrawable part into the compartment and transport them together. Only after the compartment body is erected well, the withdrawable part is allowed to push into the compartment.

3.2.5 Loose the top cover bolts of the busbar compartment and remove the cover plate.

3.2.6 Loose the fixing bolts in the front of the busbar compartment and remove the assembling partition.

3.2.7 Loose the fixing bolts of the horizontal draw-out partition under the circuit breaker compartment and remove the horizontal partition.

3.2.8 Loose and remove the cable cover plate.

3.2.9 Remove the cover plate from the left side control line raceway of the switchgear and remove the cover plate of the front right control line raceway in the same way.

3.2.10 Remove the suspension plate and fixtures.

3.2.11 Erect the switchgear on the foundation one by one and keep the alignment tolerance within 2 mm in both horizontal and vertical directions.

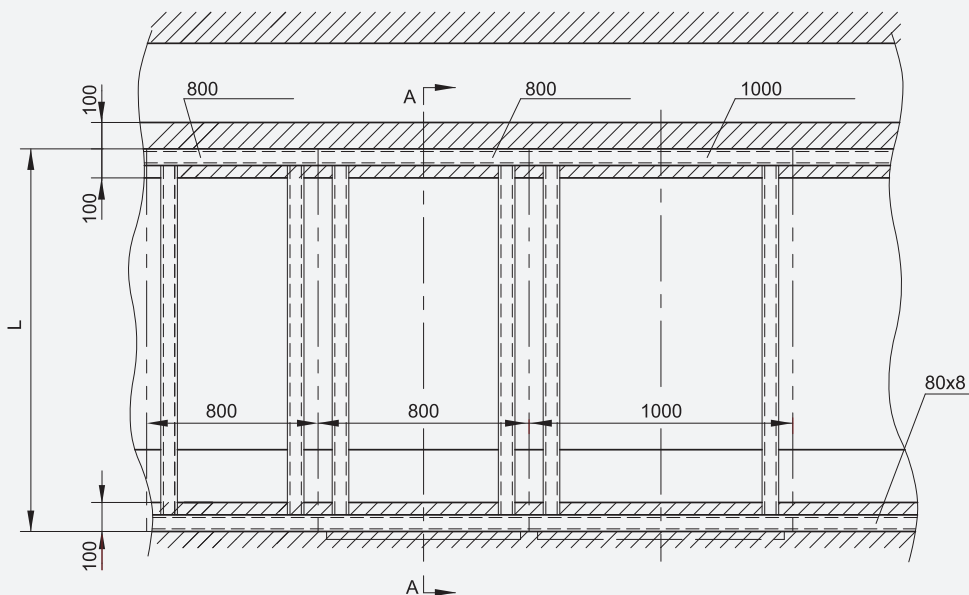

Figure 3/2 Schematic Switchgear Installation Foundation

Switchgear Depth (D)	L
1800	1760

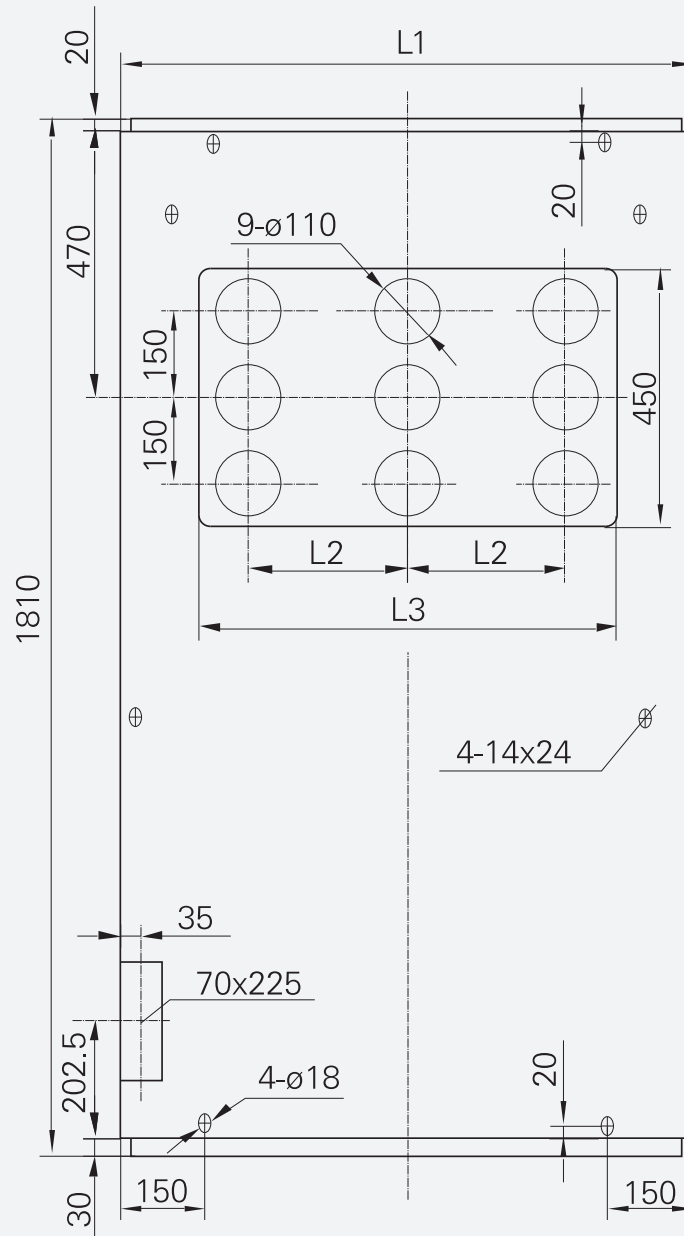

Figure 3/3 Bottom Plate Dimension

Width (W)	Depth (D)	L1	L2	L3
800	1800	800	210	530
1000	1800	1000	275	730

3.2.24 After all switchgears are erected and assembled, use M24 foundation bolts to connect them with the foundation frame together or weld them onto the foundation frame securely.

3.3 Installation of Busbar

The square busbar is used in the switchgear and they are in section form. For different current, it shall select different quantity and size of busbar and assemble them should be according to the procedures as follows:

3.3.1 Clean the busbar, check whether the insulation sleeve is damaged and then coat conductive paste or neutral Vaseline on the connection.

3.3.2 Install the main busbar in the switchgear one by one, connect the busbar section with corresponding branch busbar and tighten them with bolt. For the connection between main busbars in different switchgear, it shall use an additional main busbar connecting plate.

3.4 Earthing Device of Switchgear

3.4.1 Use pre-assembled connecting plate to connect earthing busbar of each switchgear.

3.4.2 Connect all wires inside the switchgear for necessary earthing .

3.4.3 Connect the foundation frame with earthing bar and if an array contains more than 10 sets of switchgears, it shall use 10 x 60 mm² copper bar as the earthing bar.

3.5 Check After Erection of Switchgear

(Figure 3/5)

After the switchgear is erected and located well, remove any dust or sundries inside the switchgear and check if all fixing screws are loose or not and check if all wirings are breaking. Push the withdrawable circuit breaker in and pull it out and open and close to check for abnormal condition. Adjust the meter pointer at zero and check secondary wiring for mistake according to the circuit diagram. Adjust the relay and check if the interlocks are valid or not.

4. Operation and Maintenance



Figure 3/4 Array Drawing After Completion of Erection

4.1 Cautions During Operation of Switchgear

4.1.1 Operation Procedures

Operator must operate the switchgear in accordance with the related operating procedures and this technical document. Any optional operating must be avoided and in case of trouble, any rough and forced operation without careful analysis must be avoided and otherwise equipment damage and person injury might result.

4.1.1.1 Operation of Circuit Breaker Panel Without Earthing Switch

A). Mount withdrawable circuit breaker into the panel: Before moving the withdrawable circuit breaker into the compartment, it is necessary to check the withdrawable circuit breaker whether in a good condition, whether any part or sundries are left inside the mechanism box and compartment. Put the withdrawable circuit breaker on the transfer truck and lock it well. Push the transfer truck up to the front of the switchgear and lift it to a proper height. Insert the front positioning lock plate of the transfer truck into the slot of the compartment partition and lock the transfer truck and the compartment body together. Open the locking hook of the withdrawable circuit breaker and push it into the compartment smoothly and steadily and lock it well. After the locking of withdrawable circuit breaker and compartment body is confirmed, unlock and disconnect the transfer truck from the compartment body and move it away.

B). Operation of the withdrawable circuit breaker inside the compartment: After the withdrawable circuit breaker is moved inside the compartment by transfer truck and the withdrawable circuit breaker is in disconnected/testing position, first insert the secondary plug of the auxiliary circuit to put withdrawable circuit breaker into ready operating status. With power connected, the testing position indicator on the low voltage compartment will light, and at that time, an electrical operating test could be made without connection of the main circuit. For further operation, it must close all compartment doors, insert the keys to lock the doors and confirm the circuit breaker at its opening condition (refer to clause D as below). Then insert the hand crank into the operating hole of the middle panel to turn it clockwise till the crank is obstructed obviously and hear a clear switchover sound of the auxiliary switch. In the meantime, the service position indicator on the low voltage compartment will light and then remove the hand crank. At this time, the main circuit is connected with power and the withdrawable circuit breaker is at its service position, operator can open or close the withdrawable circuit breaker via control circuit. To withdraw the withdrawable circuit breaker from its service position, it should first confirm the withdrawable circuit breaker at its opening state (Refer to point d below), insert withdrawable the circuit breaker hand crank and turn the hand crank anticlockwise till the crank is obstructed obviously and hear a clear switchover sound of the auxiliary switch. At that time, the withdrawable circuit breaker returns back its testing position, the main circuit is open completely and the shutters are closed.

C). Take the withdrawable circuit breaker out of the compartment: In order to take the withdrawable circuit breaker out of the compartment, first it should confirm the withdrawable circuit breaker in testing position, then unplug the secondary plug of the auxiliary circuit, and lock the moving plug onto the withdrawable circuit breaker frame. Push the transfer truck up to the front of the panel (as same as mounting the withdrawable circuit breaker into the compartment), unlock the truck and pull the withdrawable circuit breaker out of the compartment. After the withdrawable circuit breaker has been moved to the transfer truck completely and it is confirmed the withdrawable circuit breaker has been locked with the transfer truck, unlock the transfer truck from the compartment, move the transfer truck backwards away appropriately from the compartment and lower it down and stop. If the transfer truck shall move a long distance, it must pay more attention to prevent it from accident in transportation.

D). Confirmation of open or close state of the circuit breaker inside the compartment: A judgment be made according to the open and close indication plate on the withdrawable circuit breaker and open and close indicative lamps on the low voltage compartment. If a green opening indicative plate is shown on the circuit breaker when

operator observes through the viewing window on the panel, it could judge that the circuit breaker is at opening state. At that time, if the secondary plug of the auxiliary circuit is connected with power, the opening indicative lamp on the low voltage compartment will light.

4.1.1.2 Operation of Withdrawable Circuit Breaker Panel With Earthing Switch

The operation procedures to move the withdrawable circuit breaker in and out of the compartment are same as that for withdrawable circuit breaker without earthing switch. However, it should pay more attention during withdrawable circuit breaker operation inside the compartment and during operating the earthing switch as follows:

A. Operation of the withdrawable circuit breaker inside the compartment

To move the withdrawable circuit breaker into its service position, in addition to the operation requirements as described in 4.1.1.1, it must confirm the earthing switch in its opening condition otherwise no further operation can be done.

B. Operation of earthing switch ON and OFF

To turn on the earthing switch, first confirm the withdrawable circuit breaker has been moved backwards to its disconnected/testing position and take out the forward moving hand crank. Then push down the bending slab at the earthing switch operation hole, insert the earthing switch operating handle to turn it clockwise 90° to turn on the earthing switch. If the handle turns further anticlockwise 90°, it will turn off the earthing switch.

4.1.1.3 Operation of Isolation Truck

The isolation truck is unable to connect or disconnect load current, therefore, to push or pull the truck with load is not allowed. In operation of isolation truck inside the compartment, first it must ensure related circuit breaker truck open (see clause D of 4.1.1.1) and after the circuit breaker truck is open, it should unlock the electrical interlock between the auxiliary contact changeover and isolation truck. Only at that time, it is possible to operate the isolation truck with the specific operation procedures as same as that for withdrawable circuit breaker.

4.1.2 Cautions in Use of Interlock

4.1.2.1 There are mechanical interlocks and electrical interlocks in switchgear to ensure panel and operators in a safe condition all the time such as prevent the withdrawable circuit breaker to be pulled out or pushed in with load, prevent the circuit breaker to be incorrectly opened or closed, prevent the circuit breaker to be closed when the earthing switch is closed, prevent anybody accidentally to access into the compartment, and prevent the earthing switch to be closed in alive. However, operators must not ignore the requirement of the operating procedures. The combination of management rules and technical measures is necessary to give full play of the interlock device functions to prevent maloperation and accident.

4.1.2.2 The lock and unlock of the interlock function on this switchgear could be realized in the course of normal operation without additional operating procedures. If it is found the operation is obstructed (e.g. increasing operating obstruction), it should first check for maloperation. Never attempt to operate the equipment with extra force to damage the equipment or result a maloperation.

4.1.2.3 An emergent unlocking is allowed in any special urgent case (such as the interlock between the compartment bottom plate and earthing switch). However, it must be careful to use the emergent unlocking and frequent use of emergent unlocking should be avoided. Also necessary safeguard measures are required in use of emergent unlocking and after the urgent case is finished, the original interlock must be recovered immediately.

4.2 Cautions During Maintenance of Switchgear

In addition to the related maintenance procedures, the serviceman should pay more attention on following recommendations:

4.2.1 Check the condition of withdrawable circuit breaker in accordance with the installation and operation instructions of vacuum circuit breaker.

4.2.2 Check the operating mechanism and interlocks of withdrawable circuit breaker to meet the requirement in the instruction.

4.2.3 Check main circuit the condition, remove old grease on the fixed contact, check whether contacts are damaged, check spring for distortion, and check coating for oxidation under high temperature. Solve the problem immediately if any abnormal condition is found.

4.2.4 Check whether auxiliary circuit contact is in any abnormal condition and repair it if necessary.

4.2.5 Check whether the earthing circuit is earthed continuity such as earthing contacts, main earthing electrode and wiring between compartments.

4.2.6 Check whether fasteners are loose and retighten them if necessary.

5. Transportation and Storage

During Transportation and Storage of The Switchgear, It Should Pay Attention on Followings:

A. Toppling over, upside down and strenuous vibration must be prohibited and always keep the switchgear far from fire.

B. Protect the switchgear from raining and moisture.

C. Without permission, never attempt to disassemble the electrical apparatus and parts.

6. Documentation Completed with Switchgear

A. Product quality certificate

B. Packing list



C. Product routine test report

D. Product operation instructions



E. Secondary circuit diagram

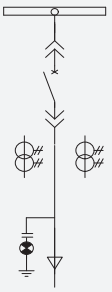
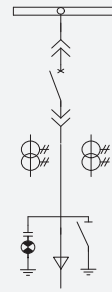
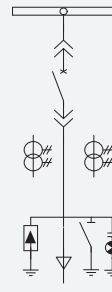

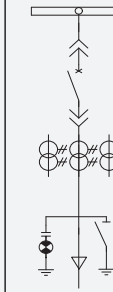
F. Special tools and transfer truck (One transfer truck is equipped for every 5 sets of switchgear if the contract number of switchgear is less than 10 sets while an extra transfer truck is provided every additional 10 sets of switchgear if the total number of switchgear is more than 10 sets.)

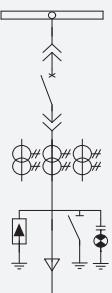
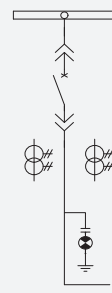
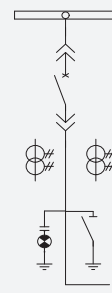
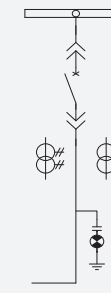
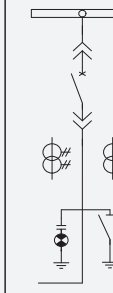

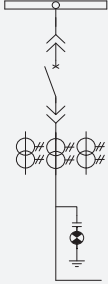
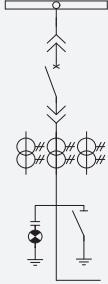
8. Primary Circuit Diagram

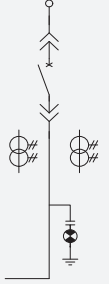
Scheme No.		001	002	003	004	005
Primary Circuit Diagram						
Rated Current (A)		630~3150				
Major Electrical Components	Vacuum Circuit Breaker	1	1	1	1	1
	Current Transformer	2	2	2	3	3
	Voltage Transformer					
	High Voltage Fuse					
	Earthing Switch		1	1		1
	Surge Arrestor			3		
Application		Receiving, Feeding	Feeding	Feeding	Receiving, Feeding	Feeding
Remarks		The switchgear is 800 mm wide. If the rated current is $\geq 1600A$, the switchgear will be 1000 mm wide.				

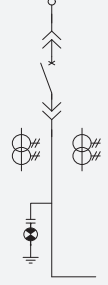
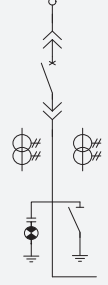
Scheme No.		006	007	008	009	010
Primary Circuit Diagram						
Rated Current (A)		630~3150				
Major Electrical Components	Vacuum Circuit Breaker	1	1	1	1	1
	Current Transformer	3	2	2	2	2
	Voltage Transformer					
	High Voltage Fuse					
	Earthing Switch	1		1		1
	Surge Arrestor	3				
Application		Receiving, Feeding	Interconnection Right	Interconnection Right	Interconnection Left	Interconnection Left
Remarks		The switchgear is 800 mm wide. If the rated current is $\geq 1600A$, the switchgear will be 1000 mm wide.				

Scheme No.		011	012	013	014	015
Primary Circuit Diagram						
Rated Current (A)		630~3150				
Major Electrical Components	Vacuum Circuit Breaker	1	1	1	1	1
	Current Transformer	3	3	3	3	2
	Voltage Transformer					
	High Voltage Fuse					
	Earthing Switch		1		1	
	Surge Arrestor					
Application		Interconnection Right	Interconnection Right	Interconnection Left	Interconnection Left	Overhead Incoming (Left Interconnection)
Remarks		The switchgear is 800 mm wide. If the rated current is $\geq 1600A$, the switchgear will be 1000 mm wide.				

Scheme No.		016	017	018	019	020
Primary Circuit Diagram						
Rated Current (A)		630~3150				
Major Electrical Components	Vacuum Circuit Breaker	1	1	1	1	1
	Current Transformer	2	2	2	3	3
	Voltage Transformer					
	High Voltage Fuse					
	Earthing Switch	1		1		1
	Surge Arrestor	3				
Application		Overhead Incoming (left Interconnection)	Overhead Incoming (Right Interconnection)	Overhead Incoming (Right Interconnection)	Overhead Incoming (left Interconnection)	Overhead Incoming (left Interconnection)
Remarks		The switchgear is 800 mm wide. If the rated current is $\geq 1600A$, the switchgear will be 1000 mm wide.				

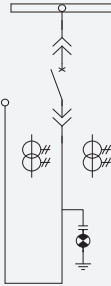
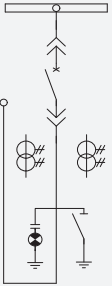
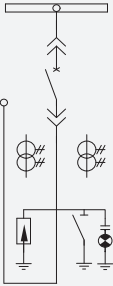
Scheme No.		021	022	023	024	025
Primary Circuit Diagram						
Rated Current (A)		630~3150				
Major Electrical Components	Vacuum Circuit Breaker	1	1	1	1	1
	Current Transformer	2	2	2	2	2
	Voltage Transformer					
	High Voltage Fuse					
	Earthing Switch		1		1	1
	Surge Arrestor					3
Application		Overhead Incoming (Right Interconnection)	Overhead Incoming (Right Interconnection)	Overhead Incoming and Outgoing	Overhead Incoming and Outgoing	Overhead Incoming and Outgoing
Remarks		The switchgear is 800 mm wide. If the rated current is $\geq 1600A$, the switchgear will be 1000 mm wide.				

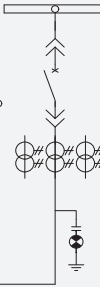
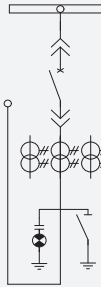
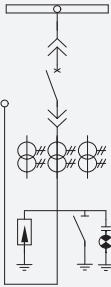
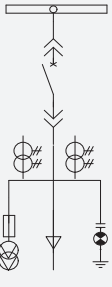
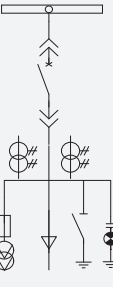
Scheme No.		026	027	028	029	030
Primary Circuit Diagram						
Rated Current (A)		630~3150				
Major Electrical Components	Vacuum Circuit Breaker	1	1	1	1	1
	Current Transformer	3	3	3	2	2
	Voltage Transformer				2	2
	High Voltage Fuse				3	3
	Earthing Switch		1	1		1
	Surge Arrestor			3		
Application		Overhead Incoming and Outgoing	Overhead Incoming and Outgoing	Overhead Incoming and Outgoing	Receiving, Feeding	Receiving, Feeding
Remarks		The switchgear is 1000 mm wide.				

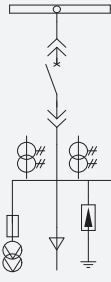
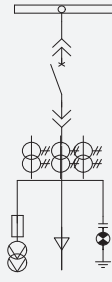
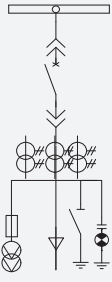
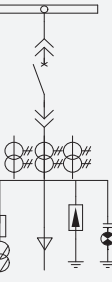
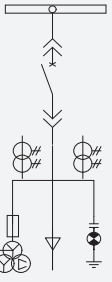
Scheme No.		031	032	033	034	035
Primary Circuit Diagram						
Rated Current (A)		630~3150				
Major Electrical Components	Vacuum Circuit Breaker	1	1	1	1	1
	Current Transformer	2	3	3	3	2
	Voltage Transformer	2	2	2	2	3
	High Voltage Fuse	3	3	3	3	3
	Earthing Switch			1		
	Surge Arrestor	3			3	
Application		Receiving, Feeding	Receiving, Feeding	Receiving, Feeding	Receiving, Feeding	Receiving, Feeding
Remarks		The switchgear is 1000 mm wide.				

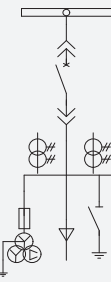
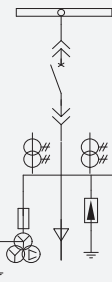
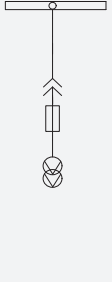
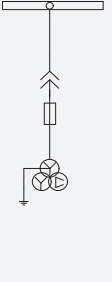
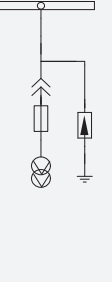
Scheme No.		036	037	038	039	040
Primary Circuit Diagram						
Rated Current (A)		630~3150				
Major Electrical Components	Vacuum Circuit Breaker	1	1			
	Current Transformer	2	2			
	Voltage Transformer	3	3	2	3	2
	High Voltage Fuse	3	3	3	3	3
	Earthing Switch	1				
	Surge Arrestor		3			3
Application		Receiving, Feeding	Receiving, Feeding	Voltage Measurement	Voltage Measurement	Voltage Measurement + Arrestor
Remarks		The switchgear is 1000 mm wide.				

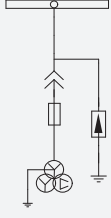
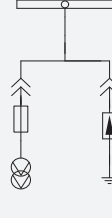
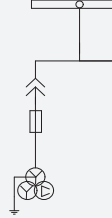
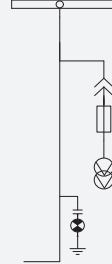
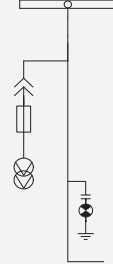
Scheme No.		041	042	043	044	045
Primary Circuit Diagram						
Rated Current (A)		630~3150				
Major Electrical Components	Vacuum Circuit Breaker					
	Current Transformer					
	Voltage Transformer	3	2	3	2	2
	High Voltage Fuse	3	3	3	3	3
	Earthing Switch					
Surge Arrestor		3	3	3		
Application		Voltage Measurement + Arrestor	Voltage Measurement + Arrestor	Voltage Measurement + Arrestor	Voltage Measurement + Bus-tie	Voltage Measurement + Bus-tie
Remarks		The switchgear is 1000 mm wide.				

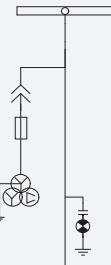
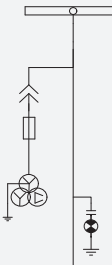
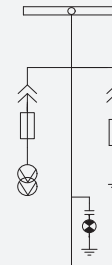
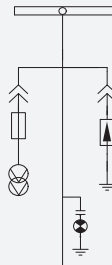
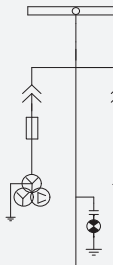
Scheme No.		046	047	048	049	050
Primary Circuit Diagram						
Rated Current (A)		630~3150				
Major Electrical Components	Vacuum Circuit Breaker					
	Current Transformer					
	Voltage Transformer	3	3	2	2	3
	High Voltage Fuse	3	3	3	3	3
	Earthing Switch					
Surge Arrestor				3	3	3
Application		Voltage Measurement + Bus-tie	Voltage Measurement + Bus-tie	Voltage Measurement + Arrestor + Bus-tie	Voltage Measurement + Arrestor + Bus-tie	Voltage Measurement + Arrestor + Bus-tie
Remarks		The switchgear is 1000 mm wide.				

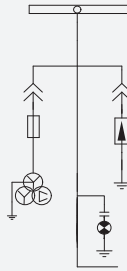
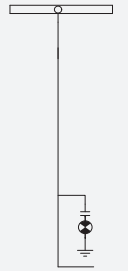
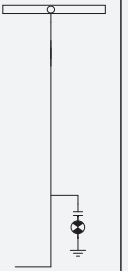
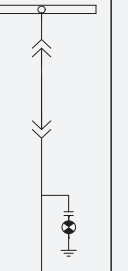
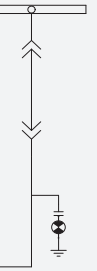
Scheme No.		051	052	053	054	055
Primary Circuit Diagram						
Rated Current (A)		630~3150				
Primary Major Electric Components and Elements	Vacuum Circuit Breaker					
	Current Transformer					
	Voltage Transformer	3				
	High Voltage Fuse	3				
	Earthing Switch					
	Surge Arrester	3				
Application		Voltage Measurement + Arrester + Bus-tie	Busbar-tie	Busbar-tie	Isolation	Isolation + (Interconnection Left)
Remarks		The switchgear is 800 mm wide. If the rated current is $\geq 1600A$, the switchgear will be 1000 mm wide.				

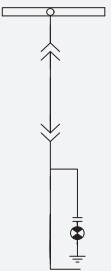
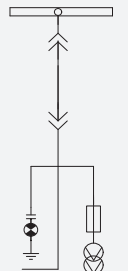
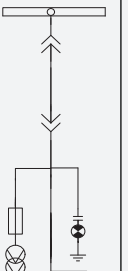
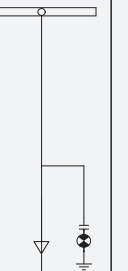
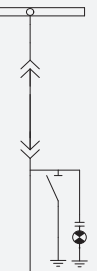
Scheme No.		056	057	058	059	060
Primary Circuit Diagram						
Rated Current (A)		630~3150				
Primary Major Electric Components and Elements	Vacuum Circuit Breaker					
	Current Transformer					
	Voltage Transformer		2	2		
	High Voltage Fuse		3	3		
	Earthing Switch					1
	Surge Arrester					
Application		Isolation + (Interconnection Right)	Isolation + Interconnection (Left) + Voltage Measurement	Isolation + Interconnection (Right) + Voltage Measurement	Cable Incoming and Outgoing	Isolation
Remarks		The switchgear is 800 mm wide. If the rated current is $\geq 1600A$, the switchgear will be 1000 mm wide.				

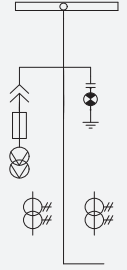
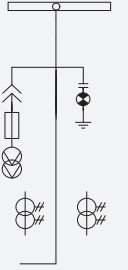
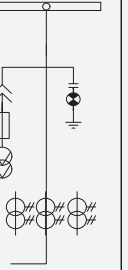
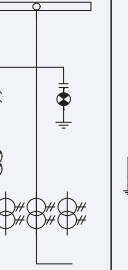
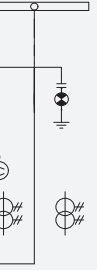
Scheme No.		061	062	063	064	065
Primary Circuit Diagram						
Rated Current (A)		630~3150				
Primary Major Electric Components and Elements	Vacuum Circuit Breaker					
	Current Transformer	2	2	3	3	2
	Voltage Transformer	2	2	2	2	3
	High Voltage Fuse	3	3	3	3	3
	Earthing Switch					
	Surge Arrestor					
Application		Metering + Inter-connection Right	Metering + Inter-connection Left	Metering + Inter-connection Left	Metering + Inter-connection Right	Metering + Inter-connection Left
Remarks		The switchgear is 1000 mm wide.				

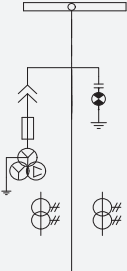
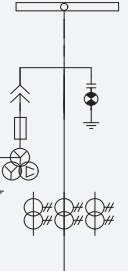
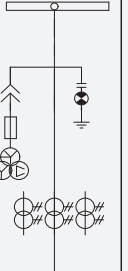
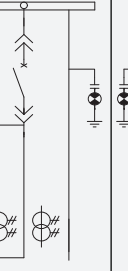
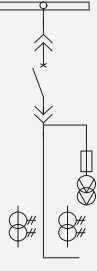
Scheme No.		066	067	068	069	070
Primary Circuit Diagram						
Rated Current (A)		630~3150				
Primary Major Electric Components and Elements	Vacuum Circuit Breaker				1	1
	Current Transformer	2	3	3	2	2
	Voltage Transformer	3	3	3	2	2
	High Voltage Fuse	3	3	3	3	3
	Earthing Switch					
	Surge Arrestor					
Application		Metering + Inter-connection Right	Metering + Inter-connection Left	Metering + Inter-connection Right	Incoming + Metering	Incoming + Metering
Remarks		The switchgear is 1000 mm wide.				

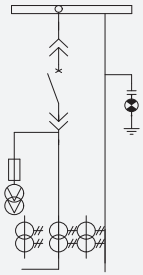
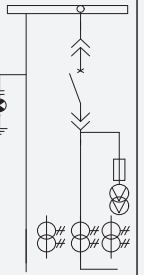
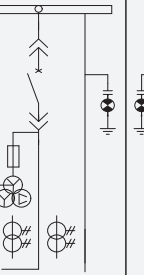
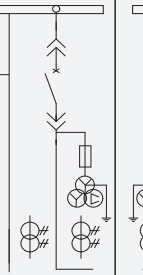
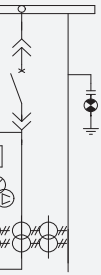
Scheme No.		071	072	073	074	075
Primary Circuit Diagram						
Rated Current (A)		630~3150				
Major Electrical Components	Vacuum Circuit Breaker	1	1	1	1	1
	Current Transformer	3	3	2	2	3
	Voltage Transformer	2	2	3	3	3
	High Voltage Fuse	3	3	3	3	3
	Earthing Switch					
	Surge Arrestor					
Application						
Remarks		The switchgear is 800 mm wide. If the rated current is $\geq 1600A$, the switchgear will be 1000 mm wide.				

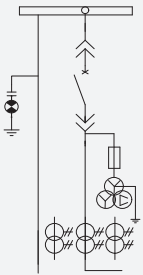
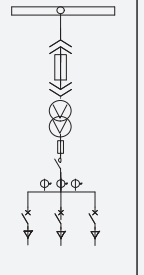
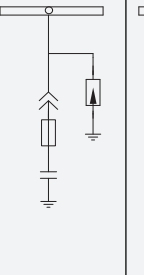
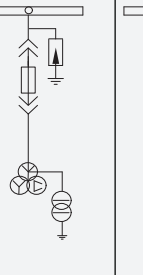
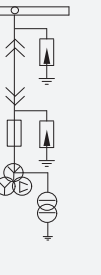
Scheme No.		076	077	078	079	080
Primary Circuit Diagram						
Rated Current (A)		630~3150				
Major Electrical Components	Vacuum Circuit Breaker	1				
	Current Transformer	3		Capacitor BM12.7-16-1 3		
	Voltage Transformer	3			4	4
	High Voltage Fuse	3	Transformet 3	3	3	3
	Earthing Switch					
	Surge Arrestor			3	3	3
Application				Capacitor		
Remarks		The switchgear is 800 mm wide. If the rated current is $\geq 1600A$, the switchgear will be 1000 mm wide.				

9. Scheme Application Example

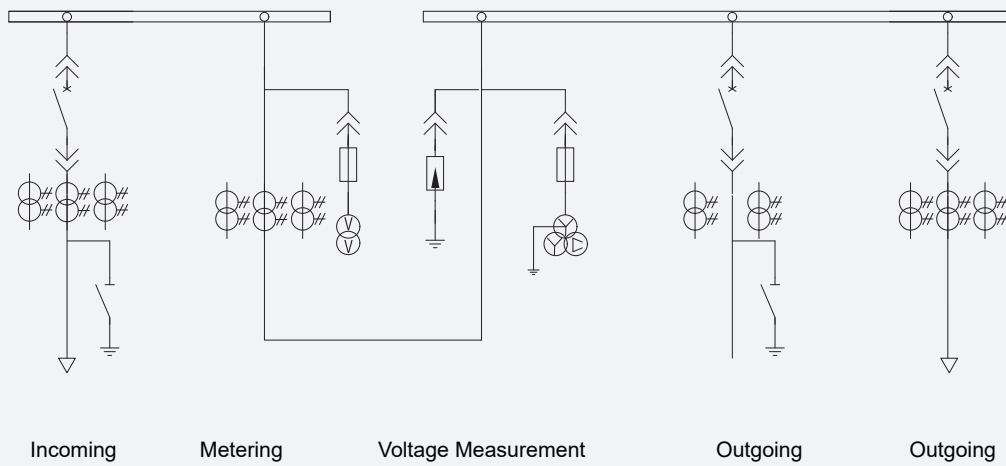

Figure 9/1 Scheme Application Example

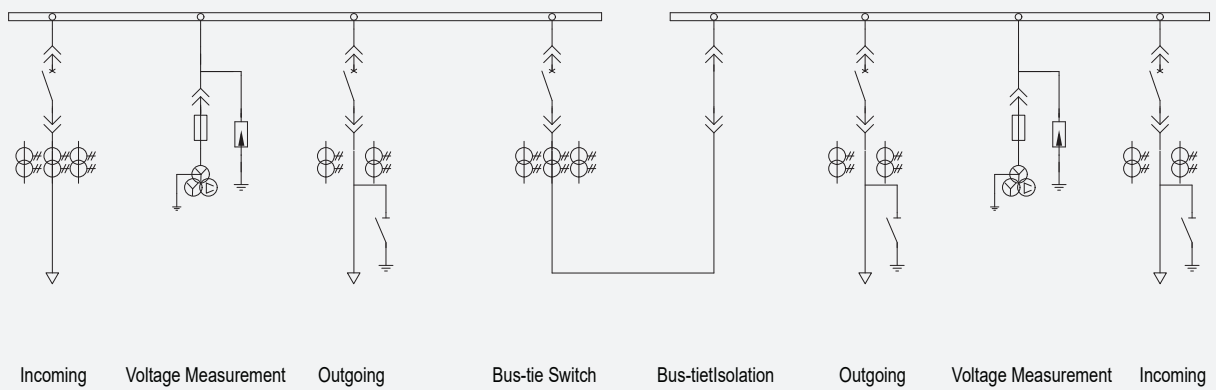

Figure 9/2 Scheme Application Example

10. Secondary Circuit Diagram

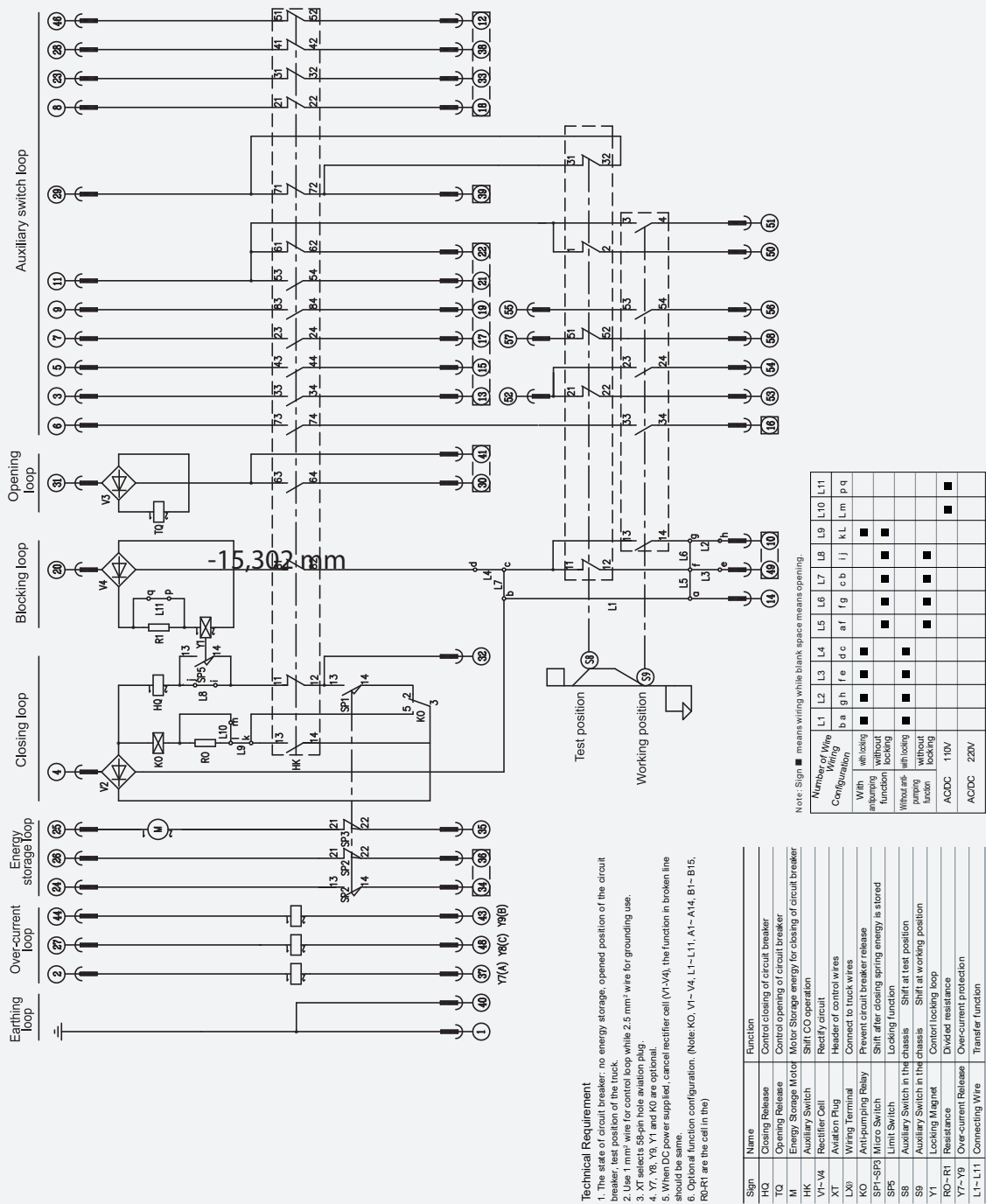

Figure 10 Electrical Circuit Diagram of VD4 Withdrawable Circuit Breaker



3B ENERGY S.r.l.

REGISTERED OFFICE

Via Villani, 2 26900 LODI (LO) - Italy

Ph. +39 0371 1856259

Fax. +39 0371 9568847

www.3b-energy.com

info@3b-energy.com